

CATALOG NUMBER	TYPE
PROJECT	

FLEXRAIL2 – LOW VOLTAGE TRACK HEAD

SERIES HM-847

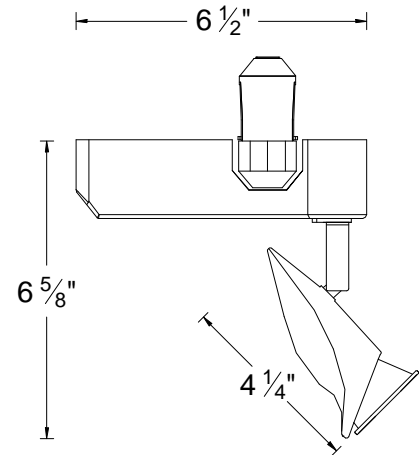
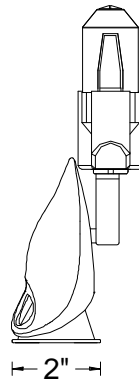

Ordering Matrix				
Series	Model		Finish	
<input type="text"/>	<input type="text"/>		<input type="text"/>	
HM	847 (50w max)	847L (75w max)	PT	BZ

Ordering Example (series number – model number – finish): HM-847L-PT

Product Details	
Description:	Flexrail2 compatible low voltage track head with integral electronic transformer. Available in either a 50w or 75w version. Utilizes MR16G lamps.
Materials:	Transformer case is molded G.E. Lexan, track assembly and head are die cast aluminum. Lamp socket is a ceramic bi-pin.
Transformer:	Electronic low voltage with auto-reset, soft start and short circuit protection features. Dimmable with electronic low voltage dimmers.
Aiming:	350° horizontal rotation and 90° vertical aiming with integral ball and swivel mounting feature. All die-cast parts assure the aiming tension is kept through continuous use and maintenance.
Lamping:	50w MR16G maximum with HM-847 model. 75w MR16G maximum with HM-847L model. MR16G glass covered lamp must be used with this fixture.
Accessories:	Use Lens Clip (LENS-16-CLIP) to add one specialty textured lens, colored lens, filter, or louver.
Finish:	Abrasion resistant platinum or bronze paint finish. PT = Platinum metal finish BZ = Designer Bronze metal finish
Listing:	UL & CUL Listed.

Specification Features
<ul style="list-style-type: none"> Architectural die-cast aluminum track head with lockable aiming and modern lamping options. Both transformer case and track head assembly are painted in a matching finish. Electronic transformer soft start feature is designed to protect lamps from abrupt inrush current. The solid state circuitry promotes cool and quiet operation. MR16 lamps available in 7, 10, 12, 15, 20, 24, 25, 30, 36, 40 & 55 degrees to allow for a wide variety of application specific lighting patterns. 5 year product warranty.