

Installation Instructions: CFL Track Fixture

Model: HTK-132E LTK-132E JTK-132E



Caution:

Read all instructions before installing.

Switch off power before installing or re-lamping.

Do not attempt to energize anything other than a track light fixture.

All installation shall be in accordance with NEC and all local codes.

To reduce the risk of a burn during re-lamping, remove from the track before re-lamping.

UL listed.

Five (5) years limited product warranty (ballast is warranted for 2 year by its manufacturer).

Mounting to track

HTK-132E is designed for use on WAC H Track;

LTK-132E is designed for use on WAC L Track;

JTK -132E is designed for use on WAC J/J2 Track;

Installing on Track:

1. Note the track has a groove running its length to indicate polarity.
2. Insert adapter into track slot and rotate it 90° the embossed arrow on the adapter should point to the grooved side of the track.(FIG 1)
3. Push up and turn the locking tab into the lock position.(FIG 2)
4. Removal is the reverse procedure. Track fixtures may be positioned anywhere along the track length.

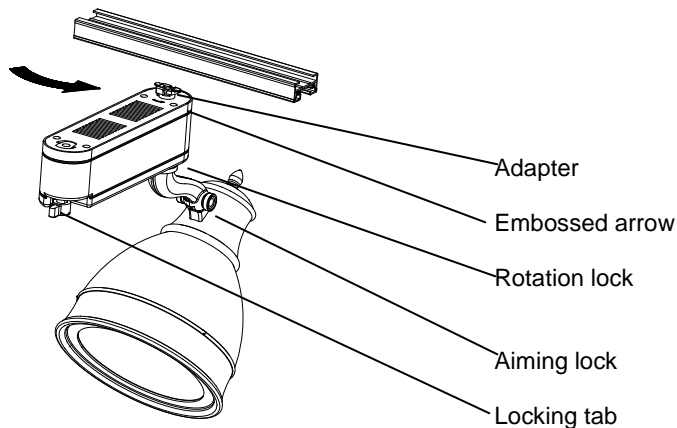

FIG 1

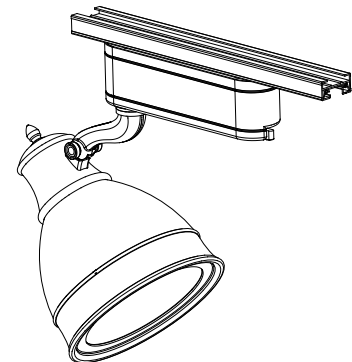
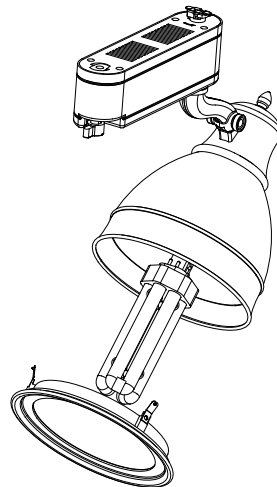

FIG 2

Re-lamping:

1. Turn power off at main switch.
2. Remove fixture from the track.
3. Pull out lens cap.
4. Use CFL tri-tube 4 pin 32W.
5. Grasp lamp and push straight into socket.
6. Re-install lens cap.



1. Compact Fluorescent lamp:
FULHAM FCFTRE32W827, 32W, 2700K
2. With 10,000 hours or more rated life.

Ballast Information

Rated Lamp Watts: 32W
Voltage: 120V
Input Current: 0.48A
Input Power (ANSI Watts): 31W
Minimum 2 years warranty from the manufacturer of the ballast.

Ballast Replacement

1. NOTE: Ballast should be replaced by a qualified electrician.
2. Loosen the screw of the lock tab.
3. Loosen the five screws of the cover.
4. Disconnect ballast from input wiring and lampholder leads (leads are terminated with either wire nuts or push release connectors on ballast).
5. Replace ballast with a Factory Approved, Energy Star qualified ballast.
6. Reinstall ballast by reversing steps 2 through step 4.

5 YEAR LIMITED PRODUCT WARRANTY

Energy Star Labeled Track Lighting

WAC Lighting warrants this product ("the product") against defects in material or workmanship for a period of five years from date of original purchase, and agrees to repair or, at the company's option, replace a defective product without charge for either replacement parts or labor during such time. This does not include labor to remove or install fixtures.

This warranty is extended only to the original purchaser of the product. A purchaser's receipt or other proof of date of original purchase acceptable to the Company is required before warranty performance shall be rendered.

This warranty only covers product failure due to defects in materials or workmanship which occurs in normal use. It does not cover the bulb or failure of product caused by accident, misuse, abuse, lack of reasonable care, alteration, or faulty installation, subjecting the product to any but the specified electrical service or any other failure not resulting from defects in materials or workmanship. Damage to the product caused by separately purchased, non-Company supplied components or bulbs, and corrosion or discoloration of components are not covered by this warranty. Also excluded from the five (5) year warranty are the HID and Fluorescent ballasts, which have a warranty from the manufacturer of the ballast and WAC will not accept any responsibility or liability on the ballasts whatsoever.

There are no express warranties except as described above.

THE COMPANY SHALL NOT BE LIABLE FOR INCIDENTAL, SPECIAL OR CONSEQUENTIAL DAMAGES RESULTING FROM THE USE OF THE PRODUCT OR ARISING OUT OF ANY BREACH OF THIS WARRANTY. ALL IMPLIED WARRANTIES, IF ANY, INCLUDING IMPLIED WARRANTIES OF MERCHANTABILITY AND FITNESS FOR A PARTICULAR PURPOSE, ARE LIMITED IN DURATION TO THE DURATION OF THIS EXPRESS WARRANTY.

Some states do not allow the exclusion or limitation of incidental or consequential damages, or limitations on how long an implied warranty lasts, so the above exclusions or limitations may not apply to you.

No other warranty, written or verbal, is authorized by the Company. This warranty gives you specific legal rights, and you may also have other rights which vary from state to state.

To obtain warranty service, please write to WAC Lighting. Enclose product model number and problems you are experiencing, along with address and telephone number. You will then be contacted with a solution or a Return Goods Authorization number and full instructions for returning the product. All returned products must be accompanied by a Return Goods Authorization Number issued by the Company and must be returned freight prepaid. Any product received without a Return Goods Authorization Number from the Company will be refused.

WAC Lighting is not responsible for merchandise damaged in transit. Repaired or replaced products shall be subject to the terms of this warranty and are inspected when packed. Evident or concealed damage that is made in transit should be reported at once to the carrier making the delivery and a claim filed with them.



Retain these instructions for future service and adjustments
615 South Street, Garden City, NY 11530
Tel: (516) 515-5000 Fax (516) 515-5050
www.waclighting.com